

Marine Anchors

Stevpris Anchor

high holding power anchor, welded type. Stevpris anchor Widely used on oil drilling platforms. With super holding power and good workmanship.

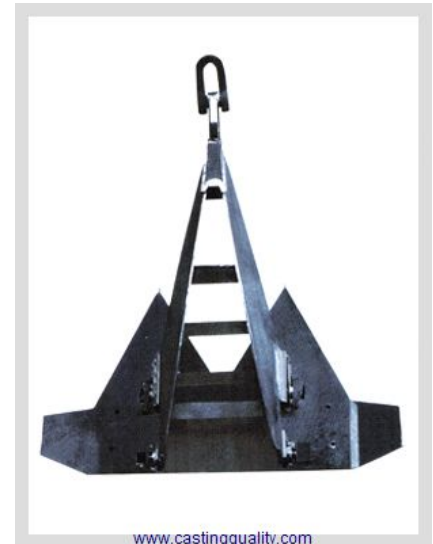

Max weight to 30tons.

Method: Sand Casting

Equipments : 20 tons electric arc furnace.

Inspection Facility:

1. Mechanical Property and Chemistry Analysis.
2. Magnetic Particle Testing
3. Penetrating Testing
4. Ultrasonic Testing
5. Radiographic Testing
6. Spectrometer

Certificated by : LR, DNV, ABS, BV, NK and GL.

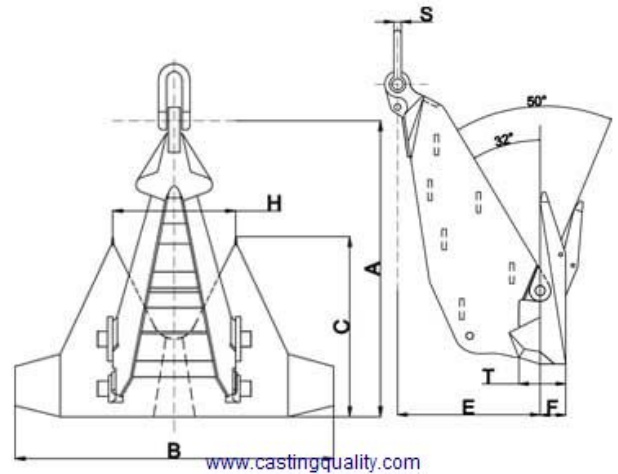

NOMINAL WEIGHT (KG)	A	B	C	E	F	H	T	S	Shackle model
1000	2580	2780	1582	1314	236	1074	430	62	a14
1500	2954	3184	1812	1505	271	1230	493	80	a17
3000	3721	4011	2283	1896	342	1550	622	90	a19
5000	4412	4756	2707	2248	406	1837	738	110	a23
7000	4910	5290	3011	2500	453	2045	825	117	a25
8000	5161	5563	3166	2629	474	2149	862	130	a37
10000	5559	5992	3410	2832	511	2315	929	140	a29
12000	5908	6368	3624	3010	543	2460	988	150	a31
14000	6219	6704	3815	3169	572	2590	1040	160	a33
15000	6364	6860	3904	3242	585	2650	1064	170	a34
18000	6763	7290	4149	3446	622	2816	1131	180	a35
20000	7004	7550	4297	3569	644	2917	1171	190	a37
22000	7230	7794	4436	3684	665	3011	1209	200	a39
25000	7545	8133	4629	3844	694	3142	1262	200	a39
30000	8018	8645	4919	4085	737	3339	1341	220	a42

Professional Supplier of Casting Parts in China